



## Draft Agenda for LBT Committee Meeting

18:00hrs, 17<sup>th</sup> July 2025

LBT Shed

1. Apologies:
2. Conflict of interest declaration
3. OHS/safety
  - Electrical power leak in the river (See attached).
4. Review minutes for 19<sup>th</sup> June 2025
5. Correspondence
  - Senior week registration (**Done by Richard Forster**)
  - Thanks, from Mike Dredge (**attached**)
6. Treasurer's Report
  - Report (**RM, Attached**)
    - Account balances: \$126,638.86
    - Events Transactions: \$ 364.86
    - Current \$61,274.60
    - Term Deposit 2 \$65,000.00
  - WBC pontoon rent (From previous meeting, **update?**)
7. Subcommittee reports
  - Management Subcommittee
    - No meeting yet
    - LBT Secretary > Need to find solution at next AGM
    - Tasmanian Men's Shed Capital Investment Grants awarded
      - Contract from granting body received (**Attached**)
      - Engineer opinion and new quote (PL)
      - Move boulders to facilitate bringing boats on the grass (Henk)
    - Men's Shed grant (Saw Stop) – successful > **Action – Installation**
    - Brass plaque for "John and Ruth Young pontoon" > Received  
**Action:** Huon pine base being made
  - Skiff Subcommittee
    - St Ayles Skiff oars, no update from Port Esperance Sailing Club
  - Community Engagement Subcommittee
    - No meeting held since last LBT Committee
    - Request for loan of equipment (**Attached**)
    - Launch celebration of new Jetties, now 25 July. **Action:** Liaise to confirm with WBC.
    - Arrangement for LBT dinner during concrete works, postponed until new date for concreting
    - Senior's week organisation
    - Egg Island transportation for Land Conservancy (**Postponed**)
    - 1<sup>st</sup> aid course participants who missed it (3) can still do it later.
  - Boating Subcommittee
    - Upgrade to rigging of Grebes completed
    - Friday Grebes sailing still going
    - Knot making course organised by Ed.
    - Aluminium Safety Boat and trailer



- Shannon: experience from Pip
  - Tasmanian Sail and Oar Expedition 2026 (i.e. Mini Raid, JP)
  - Need for a plan to keep LBT raid boats in good shape
  - The use of the pontoon (near Cartela) by visiting boats, to use booking and payment system. Rules to be written - **Action Sailing Subcommittee.**
  - Shipwright and Facilities management Subcommittee
    - No meeting
    - Lady Dot now in shed of Peter Tonkin for restoration
    - Dish washer (AR)
    - CCTV (AR)
    - Stolen trailer wheels
    - Stability of Viking
    - Capricornia
      - What do we do while concrete is being installed in the shed?
    - Gantry update
    - Nancy –Need to find electrician who can do electrical work
    - Nancy – out-of-water survey completed, needs some repair (**attached**)
    - Power tool induction
8. Calendar:
- |           |   |
|-----------|---|
| July 25   | Opening of pontoons (TBC)                     |
| Quarter 4 | Huonville Primary School on-the-water program |
9. New Members
10. General Business
11. Any other business.
- 
12. Next Meeting

**Fwd: Re: Cartela - electrical**

**From** LBT Secretary <sec@lbt.org.au>  
**To** <president@lbt.org.au>  
**Date** 2025-07-12 21:00

**From:**

Niall Smith &lt;niall@njselec.com&gt;

**Sent:** 12 July 2025 8:23:01 pm AEST**To:**

Tim Oxley &lt;oxley.tim@gmail.com&gt;

**Cc:**

Ian Kuhl &lt;Ian@franklinmarine.com.au&gt;, Living Boat Trust &lt;sec@lbt.org.au&gt;, George Rance &lt;garance370@gmail.com&gt;

**Subject:**

Re: Cartela - electrical

Good evening everyone,

To give a summary of the situation, I have installed a new main switchboard, temporary lights and temporary power onboard the Cartela, during my testing today I've found a stray current of around 10 amps flowing through the earthing system onboard and back to shore supply, I've had Tasnetworks onsite to rule out any issues with the power supply to the area.

This stray current remains while the vessel is powered down and the power to the switchboard on the wharf is turned off, this rules out any issues with the Cartela, none of the old electrical system is connected at all.

My thoughts on the cause are as follows

- A vessel in the nearby marina has a large amount of electrical leakage
- A nearby building has a fault within its internal wiring/switchboard
- Damaged underground wiring
- An extension lead has fallen in the water and is not on an RCD protected circuit

All of these issues would go fairly unnoticed, would not effect the normal operation of the buildings and vessels involved but should be easy find and rectify.

The best way for me to potentially find where the power is coming from is to be able to gain access to switchboards within any buildings close by and unplug any vessels that are connected to shore supply briefly to test if the stray current goes away.

My concerns with the situation is if another boat is causing this issue it will be the victim of corrosion damage and it will most likely be happening without any knowledge to the owners.

If it happens to be a building, someone is losing a fair amount of power which they would be paying for and could be something as simple as a faulty appliance, once again fairly easy to find and rectify.

There are measures I can put in place to protect the Cartela from the stray current but this isn't fixing the cause of the problem, more a last resort to protect her.

The only reason this has been picked up is that for electrical compliance for the works undertaken on the Cartela, I have certain tests I have to undertake that only get done on a new electrical installation, in other words it's could have been happening for years completely unnoticed.

If anyone is getting an unusually large power bill that would be a great starting point.

Regards  
Niall Smith  
Njs Electrical & Marine Pty Ltd  
4 Hornby Road  
Goodwood, Tas, 7010



On Sat, 12 Jul 2025 at 13:51, Tim Oxley <[oxley.tim@gmail.com](mailto:oxley.tim@gmail.com)> wrote:

Ian and Richard,

Electrician Niall Smith has advised that there is extra electrical current in the water in the vicinity of Cartela.

This may be affecting other boats.

Are you aware of any electrical issues?

I have copied Niall in case he is needed.

Let me know.

Thanks,

Tim

LBT Secretary

## Treasurer's Report – 3 Months to 2025-07-14

Our major expenditure in the last 3 months was for tools (main item safety saw)(\$4951), a ladder for the new pontoon (\$1820), the crown lease (\$1300), fleet materials (\$1295) and the slipping plus survey of Nancy (required for insurance)(\$900). Income came from memberships (\$724), interest on our term deposits (\$2166) and Monday dinners (\$997). The held funds item represents donations by TN25 participants to the safety boat crews. This will be distributed once Martin Riddle is back.

In June we moved part of our term deposit funds into our working bank account, leaving \$65,000 in term deposit. The reason for this was that the profit from the Tawe Nunnagah, though significant, was not as high as we had hoped. This was mainly due to greater than expected expenditures. For the coming year(s) we are facing a similar problem to the Tasmanian Government. That is, insufficient revenue for our spending aspirations.

This report spans the end of the financial year. The financial report for 24/25 will be presented (as always) at the AGM.

I have been away for a large part of the previous 3 months. Treasurer duties were capably managed by our president JP Scheerlinck.

| INCOME ACCOUNT   | AMOUNT             | PERCENTAGE |
|------------------|--------------------|------------|
| Held Funds       | \$5,617.00         | 41.4 %     |
| Memberships      | \$4,454.74         | 32.8 %     |
| Bank Interest    | \$2,166.08         | 16.0 %     |
| Monday dinners   | \$997.91           | 7.4 %      |
| Donations        | \$181.00           | 1.3 %      |
| Boat Parking     | \$159.09           | 1.1 %      |
| Credit card fees | -\$30.74           | -          |
| <b>Total</b>     | <b>\$13,545.08</b> |            |

Notes: Percentage is calculated on positive amounts only

| EXPENSE ACCOUNT            | AMOUNT             | PERCENTAGE |
|----------------------------|--------------------|------------|
| Tools                      | \$4,951.82         | 38.2 %     |
| Capital expenses           | \$1,820.00         | 14.0 %     |
| Crown lease                | \$1,300.00         | 10.0 %     |
| Fleet materials            | \$1,295.70         | 10.0 %     |
| Nancy maintenance          | \$900.00           | 6.9 %      |
| WBC rent                   | \$714.00           | 5.5 %      |
| TN25_General               | \$500.00           | 3.9 %      |
| Water                      | \$287.20           | 2.2 %      |
| Kitchen & toilet materials | \$267.46           | 2.1 %      |
| Shed materials             | \$227.80           | 1.8 %      |
| All other expense accounts | \$691.17           | 5.4 %      |
| <b>TOTAL</b>               | <b>\$12,955.15</b> |            |

### Bank account list

The Living Boat Trust  
By status

| DESCRIPTION              | TYPE | LAST RECONCILED | CURRENT BALANCE |
|--------------------------|------|-----------------|-----------------|
| <b>OPEN ACCOUNTS</b>     |      |                 |                 |
| Bendigo 149496275        | Bank | 30 June 2025    | \$61,067.85     |
| Bendigo Event Debit      | Bank | 30 June 2025    | \$342.86        |
| Bendigo Term Deposit 672 | Bank | 30 June 2024    | \$0.00          |
| Bendigo Term Deposit 730 | Bank | 31 Dec 2024     | \$65,000.00     |
| Petty cash               | Bank | 30 June 2025    | \$135.10        |

#### Reserved Funds April 12:

|                            |            |
|----------------------------|------------|
| Historic skiff fundraising | \$3,925.11 |
| Krynen Nancy bequest       | \$2,102.19 |

#### Membership Status July 14:

72 financial members consisting of 26 Individual, 23 Associate, 15 Family, 0 Workshop, 1 Corporate and 7 Life.

Rod Macfarlan,  
Treasurer, 14 July, 2025

**Re: [LBT Committee] Thanks** 

**From** [Jean-Pierre Scheerlinck](#)  
**Sender** [Committee](#)  
**To** [flatcalm@ozemail.com.au](mailto:flatcalm@ozemail.com.au)  
**Cc** [LBT Committee](#)  
**Date** Sat 19:14

 [Summary](#)  [Headers](#)  [Plain text](#)

Dear Mike,

Thanks for the feedback. You had indeed the best of weather. I will pass on your message to the LBT Committee.

Regards

**Jean-Pierre Y. Scheerlinck,**  
**M:** +61 402584108  
**E:** [j.scheerlinck@unimelb.edu.au](mailto:j.scheerlinck@unimelb.edu.au)

---

**From:** flatcalm@ozemail.com.au <flatcalm@ozemail.com.au>  
**Date:** Saturday, 21 June 2025 at 7:10 pm  
**To:** Jean-Pierre Scheerlinck <j.scheerlinck@unimelb.edu.au>  
**Subject:** [EXT] Thanks

**External email:** Please exercise caution

---

Hi JP

Could I ask you to thank the committee (and yourself) for the offer of gratis use of the Nancy. It wasn't needed, and wasn't expected - the old family acquaintances whom we took out for an ashes scattering event were more than happy to contribute to the Nancy fund and can well afford to do so.

As it turned out we had a perfect day - glassy calm, sunny and every detail of the day worked out as planned. Had a tot of good whiskey to remember a long life while on board and a good meal afterwards.

But I very much appreciated the thought behind your offer - the LBT is a core organisation in Franklin and the connections it gives for a lot of people are so valuable in a community like ours.

Regards

Mike Dredge

---

---  
Committee mailing list  
[Committee@lbt.org.au](mailto:Committee@lbt.org.au)  
[http://lbt.org.au/mailman/listinfo/committee\\_lbt.org.au](http://lbt.org.au/mailman/listinfo/committee_lbt.org.au)



## Grant deed

Grant program: Tasmanian Men's Sheds Capital Investment Grants Program 2025

MS-CI-25-013: Concrete Flooring Installation

---

The Crown in Right of Tasmania  
(represented by the Department of Premier and Cabinet)  
**(Grantor)**

and

Living Boat Trust Inc  
**(Recipient)**

OCS APPROVED TEMPLATE  
Grant Docs-Grant deed (short form) template-3-2014-AU  
(December 2014)

REFERENCE AND CONTACT DETAILS  
Department: Department of Premier and Cabinet  
Address: 21 Kirksway Place, Hobart TAS 7000  
Contact officer: *Community Grants and Programs*  
Telephone: 1800 204 224  
Email: grants@dpac.tas.gov.au  
CM Ref: GC4623

Grant Deed - Living Boat Trust Inc - Concrete Flooring Installation - MS-CI-25-013  
Document ref: DPAC – Grant Deed (Short Form) Template – V.140125

# Contents

---

|   |           |
|---|-----------|
| <b>Details and recitals</b>                                     | <b>1</b>  |
| <b>Information Table</b>  | <b>2</b>  |
| <b>1 Definitions and interpretation</b>                         | <b>2</b>  |
| 1.1 Definitions   | 2         |
| 1.2 Interpretation  | 7         |
| 1.3 Headings  | 8         |
| 1.4 No rule of construction applies to disadvantage party       | 8         |
| 1.5 Information Table   | 8         |
| <b>2 Grant</b>  | <b>9</b>  |
| 2.1 Agreement to provide Grant                                  | 9         |
| 2.2 Acknowledgments   | 9         |
| <b>3 Payment of Grant to Recipient</b>                          | <b>9</b>  |
| 3.1 Method of Grant payment                                     | 9         |
| 3.2 Conditions affecting Grant payment                          | 9         |
| <b>4 Application of Grant and related matters</b>               | <b>9</b>  |
| 4.1 Application of Grant for Approved Purpose                   | 9         |
| 4.2 Commencement of Approved Purpose                            | 10        |
| 4.3 Completion of Approved Purpose                              | 10        |
| 4.4 Compliance with Law   | 10        |
| 4.5 Financial records   | 10        |
| 4.6 Notice by Recipient of adverse matters                      | 10        |
| <b>5 Publicity concerning Grant and Approved Purpose</b>        | <b>10</b> |
| <b>6 Repayment of Grant by Recipient</b>                        | <b>10</b> |
| 6.1 Repayment obligation  | 10        |
| <b>7 Review, monitoring, audit, reports and related matters</b> | <b>10</b> |
| 7.1 Review, monitoring or audit of Relevant Matters             | 10        |
| 7.2 Reporting   | 10        |
| <b>8 Representations and warranties</b>                         | <b>11</b> |
| 8.1 Warranties  | 11        |
| 8.2 No reliance by the Recipient                                | 11        |
| <b>9 Default Events and termination</b>                         | <b>11</b> |
| 9.1 Default Events  | 11        |
| 9.2 Termination - Default Events                                | 11        |
| <b>10 Special terms and conditions</b>                          | <b>11</b> |
| <b>11 GST</b>   | <b>11</b> |
| <b>12 Notices</b>   | <b>11</b> |
| 12.1 Notice requirements  | 11        |

|           |   |           |
|-----------|---|-----------|
| 12.2      | Method and address for delivery                 | 11        |
| 12.3      | Time of receipt                                 | 11        |
| <b>13</b> | <b>Miscellaneous</b>                            | <b>11</b> |
| 13.1      | Governing law                                   | 14        |
| 13.2      | Dispute jurisdiction                            | 15        |
| 13.3      | Entire agreement clause                         | 15        |
| 13.4      | Liability                                       | 15        |
| 13.5      | Benefit   | 15        |
| 13.6      | Severance                                       | 15        |
| 13.7      | Counterparts                                    | 15        |
| 13.8      | Further assurance                               | 15        |
| 13.9      | No partnership or agency                        | 15        |
| 13.10     | Legal costs                                     | 16        |
| 13.11     | Amendment                                       | 16        |
| 13.12     | Waiver  | 16        |
| 13.13     | Successors and assigns                          | 16        |
| 13.14     | Rights cumulative                               | 16        |
| 13.15     | Set-off   | 16        |
| 13.16     | No assignment                                   | 16        |
| 13.17     | Disclosure                                      | 16        |
| 13.18     | Determination                                   | 17        |
| 13.19     | Consent and approvals                           | 17        |
| 13.20     | Doctrine of merger                              | 17        |
| 13.21     | No interference with executive duties or powers | 17        |
| 13.22     | Surviving provisions and termination            | 17        |
|           | <b>Signing</b>                                  | <b>19</b> |
|           | <b>Annexure A – Acknowledgement of Funding</b>  | <b>20</b> |

# Grant deed

## Details and recitals

---

### Date:

### Parties:

---

|                 |  |
|-----------------|--|
| Name            | <b>The Crown in Right of Tasmania</b><br>(represented by the Department of Premier and Cabinet)  |
| Short form name | <b>Grantor</b>   |
| Notice details  | Department of Premier and Cabinet,<br>Community Grants and Programs,<br>21 Kirksway Place, Street, Hobart TAS 7000<br>Phone: 1800 204 224<br>Email: grants@dpac.tas.gov.au |

---

|                 |  |
|-----------------|--|
| Name            | <b>LIVING BOAT TRUST INC</b>   |
| ACN/ARBN/ABN    | 76554208263  |
| Short form name | <b>Recipient</b>   |
| Notice details  | 3337 Huon Hwy, Franklin, TAS, 7113<br>Phone: 0402 584 108<br>Email: President@lbt.org.au<br>Attention: Dr Jean-Pierre Scheerlinck, President |

---

### Recitals:

- A. The Grantor has agreed to provide a monetary grant to the Recipient upon the terms and conditions set out in this Deed.
- B. The Recipient has agreed to accept the Grant on the terms and conditions set out in this Deed.

# Information Table

**Item 1 (clause 1.1): Approved Purpose for which the Grant is provided**

The Approved Purpose is to assist the Recipient to install a new concrete floor inside the Living Boat Trust Shed and under its covered veranda, to improve safety, accessibility, and functionality, as outlined in their application, MS-CI-25-013 (**the Project**).

**Item 2 (clause 2.1): Grant Amount**

The amount of the Grant is **\$35,000.00** (excluding GST).

**Item 3 (clause 3.1): Payment method for the Grant**

The Grant is to be paid to the Recipient within 15 Business Days after the date of this Deed by electronic funds transfer to the following account held by the Recipient:

Account name: Living Boat Trust  
BSB: 633000  
Account number: 149496275

Payment is subject to the Grantor receiving:

- a correct rendered tax invoice; and
- satisfactory evidence confirming that the above account is held in the name of the Recipient.

*Acceptable evidence may include a bank statement, a letterhead showing the BSB and account number, or a signed statement from the Recipient's finance officer.*

**Item 4 (clause 3.2(a)): Conditions precedent to payment of the Grant**

**The payment of the Grant (or any instalment thereof) is subject to the following Conditions Precedent:**

1. The Parliament of Tasmania appropriates to the Grantor the funds necessary to pay the Grant to the Recipient.
2. The Recipient must have complied with all outstanding reporting obligations under any previous funding arrangements with the Department of Premier and Cabinet, to the satisfaction of the Grantor.
3. Where the Grant is to be paid in instalments, each instalment is further subject to the timely and satisfactory submission of the corresponding report(s) specified in Item 11 (Reporting Requirements).

No payment will be made until the relevant Conditions have been satisfied. Upon satisfaction, the Grantor will make the payment upon receipt of a correctly rendered tax invoice from the Recipient.

**Item 4 (clause 3.2(a)): Conditions precedent to payment of the Grant**

**Additional Conditions for Infrastructure Projects:**

- i. A copy of an approved development or building application from the relevant Local Government Authority, if required; and/or
- ii. Evidence of freehold or leasehold arrangements for a minimum period of three (3) years. Where the site is not owned by the Recipient, written consent from the landowner for the proposed works must be provided.

**Item 5 (clause 4.2): Date for commencement of the Approved Purpose**

The date for commencement of the Approved Purpose is 3 June 2025.

**Item 6 (clause 4.3): Date for completion of the Approved Purpose**

The date for completion of the Approved Purpose is 30 June 2026.

**Item 7 (clause 7.2): Reporting requirements**

The Recipient must provide to the Grantor:

- (a) **Activity Report** – due by **31 December 2025** (For the period between 03/06/2025 to 30/11/2025) includes:
  - i. a written summary outlining the Recipient’s progress in delivering the Project in accordance with the Approved Purpose;
  - ii. an updated timeline or projected date for completion;
  - iii. a description of any issues, delays, or risks that may impact delivery of the Project; and
  - iv. documented financial evidence showing how the Grant Funds have been expended to date.
- (b) **Final Report** – due by **31 December 2026** (For the period between 03/06/2025 to 30/06/2026) includes:
  - i. a written summary describing how the Recipient has completed the Project in accordance with the Approved Purpose;
  - ii. submission of an online financial acquittal declaration, including documented financial evidence showing how the Grant Funds have been expended;
  - iii. one or more photographs showing the completed works; and
  - iv. where applicable, copies of any required planning approvals, building permits, or compliance certificates relating to the completed works.

In addition, the Recipient must provide a copy of the organisation’s most recent **audited financial report** or the **financial report tabled at its most recent Annual General Meeting (AGM)**.

**Note:**

All other reports and documents that the Grantor requires under Item 7 (clause 7.2) must be provided by the Recipient within 20 Business Days of the requirement being notified to the Recipient.

**Item 7 (clause 7.2): Reporting requirements**

The form and substance of each report or document (including each document submitted with, or as part of, a report) provided by the Recipient to the Grantor under this Deed must be satisfactory to the Grantor, acting reasonably.

**Item 8 (clause 10): Special terms and conditions****Special Condition 1 – Relevant qualifications, licences, permits, approvals or skills**

The Recipient agrees to ensure that personnel performing work in relation to the Approved Purpose:

- (a) are appropriately qualified to perform the tasks indicated;
- (b) have obtained all necessary and appropriate qualifications, licences, permits, approvals and skills necessary to perform the tasks indicated in a manner lawfully and consistent with good industry practice before performing any part of the Approved Purpose; and
- (c) continue to maintain all qualifications, licences, permits, approvals and skills referred to in this Special Condition 1 for the duration of their involvement in the Approved Purpose.

**Special Condition 2 – Recipient responsible for further funds**

Without affecting clause 2.2, the Recipient acknowledges and agrees that the Grant provided is only a contribution towards carrying out the Approved Purpose and the Recipient must provide, or secure from one or more other sources, all remaining funds required for the completion of the Approved Purpose.

**Special Condition 3 – Maintenance of Funded Infrastructure**

For the purposes of this Special Condition, *Funded Infrastructure* means buildings, facilities, or fixtures that are constructed, renovated, or improved using the Grant.

- (a) The Recipient must take reasonable steps to maintain the Funded Infrastructure in good condition.
- (b) The Recipient is responsible for all ongoing costs associated with the use, maintenance, and operation of the Funded Infrastructure, including after the end of the Grant period.

**Special Condition 4 – Adverse effects or material delays impacting performance**

The Recipient agrees, as per Clause 4.6, to notify the Grantor in writing of the occurrence of any matter, event or thing, occurring after the date of this Deed, that adversely affects or materially delays the Recipient carrying out the Approved Purpose in accordance with, or the performance by the Recipient of its obligations under this Deed.

**Special Condition 5 – Reimbursement of Pre-Execution Costs**

The Recipient may use the Grant Funds to reimburse eligible expenditure incurred in relation to the Approved Purpose from the Commencement Date, notwithstanding that this Deed may be executed after that date. Such expenditure must be:

- (a) directly related to the Approved Purpose;
- (b) reasonable and properly documented; and

**Item 8 (clause 10): Special terms and conditions**

- (c) incurred within the grant term and in accordance with the other terms of this Deed.

**Special Condition 6 – Acknowledgement of support**

In addition to, and without limitation to clause 5 of this Deed, the Recipient must comply with the provisions of Annexure A in relation to providing acknowledgement of the Grantor's support.

**Special Condition 7 – Caretaker Arrangements**

The Recipient acknowledges that this Deed has been entered into during the “caretaker period” (“**Caretaker Period**”) in respect of the 2025 Tasmanian State election (“**Election**”). The Recipient acknowledges that:

- (a) the incoming government elected pursuant to the Election may not wish to proceed with this Deed and the Grantor may terminate this Deed by giving written notice to the Recipient; and/or
- (b) the payment of the Grant (or any instalment of the Grant) is subject to the Conditions Precedent in Item 4.

# Agreed terms and conditions

---

The parties agree as follows:

---

## 1 Definitions and interpretation

### 1.1 Definitions

In this Deed, unless the context otherwise requires:

**Approved Purpose** means the purpose for which the Grant is provided as set out in Item 1.

**Authorised Officer** means:

- (a) if a party is the Crown or a Minister of the Crown, each of the Secretary of the department responsible for the administration of the Grant, an Acting Secretary of that department, a Deputy Secretary of that department, and a nominee of any of them; or
- (b) for any other party, a person authorised in writing by that party.

**Business Day** means a day that is not a Saturday, a Sunday, Easter Tuesday or a statutory holiday (as defined in the *Statutory Holidays Act 2000* (Tas)) generally observed in Hobart.

**Crown** means the Crown in Right of Tasmania.

**this Deed** means this deed and includes all its annexures, appendices, attachments and schedules (if any).

**Default Event** means each of the events specified in clause 9.1.

**Details** means the details and recitals set out above.

**Government Body** includes a body politic, a government (federal, state or local), a governmental, judicial or administrative body, a tribunal, a commission, a department or agency of any government, and a statutory authority or instrumentality.

**Grant** means the grant paid, or to be paid, by the Grantor to the Recipient pursuant to clause 2.1.

**Grantor** means the person or entity named above as Grantor and, where the context requires, includes the employees, authorised contractors and agents of that person. If the Grantor is a Minister of the Crown, a reference to the Grantor includes that Minister's predecessors and successors in office (as applicable).

**GST** means any goods and services tax or similar tax imposed by the Commonwealth of Australia (but excluding any penalty, fine, interest or similar payment).

**GST Laws** means applicable Laws relating to GST.

**Information Table** means the table titled 'Information Table' set out above.

**Item** means an item in the Information Table.

**Law** means:

- (a) principles of law or equity established by decisions of courts;

- (b) legislation and subordinate legislation; and
- (c) requirements, approvals (including conditions) and guidelines of any Government Body that have force of law.

**month** means calendar month.

**Recipient** means the person named above as the Recipient and, where the context requires, includes the officers and employees of the Recipient.

**Relevant Matter** means any matter or thing related to any of the following:

- (a) the performance by the Recipient of its obligations under this Deed;
- (b) the receipt, use or expenditure of the Grant;
- (c) the carrying out of the Approved Purpose (including the effectiveness of the Recipient's carrying out of the Approved Purpose);
- (d) any report provided, or to be provided, by the Recipient to the Grantor in accordance with this Deed;
- (e) any information provided by the Recipient to the Grantor in connection with any application for the Grant;
- (f) any breach of this Deed by the Recipient;
- (g) the occurrence, or possible occurrence, of any Default Event.

**Right** includes a right, a power, a remedy, a discretion or an authority.

## 1.2 Interpretation

In this Deed, unless the context otherwise requires:

- (a) the singular includes the plural and vice versa;
- (b) words importing a gender include all genders;
- (c) other parts of speech and grammatical forms of a word or phrase defined in this Deed have a corresponding meaning;
- (d) a reference to a thing (including property or an amount) is a reference to the whole and each part of that thing;
- (e) a reference to a group of persons includes a reference to any one or more of those persons;
- (f) a reference to an annexure, an appendix, an attachment, a schedule, a party, a clause or a part is a reference to an annexure, an appendix, an attachment, a schedule or a party to, or a clause or a part of, this Deed;
- (g) a reference to any legislation or legislative provision includes subordinate legislation made under it and any amendment to, or replacement for, any of them;
- (h) writing includes marks, figures, symbols, images or perforations having a meaning for persons qualified to interpret them;
- (i) a reference to a document includes:
  - (i) any thing on which there is writing;

- (ii) any thing from which sounds, images or writings can be reproduced with or without the aid of any thing else;
- (iii) an amendment or supplement to, or replacement or novation of, that document; or
- (iv) a map, plan, drawing or photograph;
- (j) a reference to an agreement includes an undertaking, deed, agreement or legally enforceable arrangement or understanding, whether or not in writing;
- (k) a reference to a 'person' includes a natural person, a partnership, a body corporate, a corporation sole, an association, a Government Body, or any other entity;
- (l) a reference to a party includes that party's executors, administrators, successors and permitted assigns and substitutes;
- (m) a reference to a Minister includes, as applicable, that Minister's predecessors and successors in office;
- (n) a reference to a Government Body or other body or organisation that has ceased to exist, or that has been renamed, reconstituted or replaced, or the powers or functions of which have been substantially transferred, is taken to refer respectively to the Government Body or other body or organisation as renamed or reconstituted, or established or formed in its place, or to which its powers or functions have been substantially transferred;
- (o) a reference to an office in a Government Body or other body or organisation includes any person acting in that office, and if the office is vacant, the person who for the time being is substantially responsible for the exercise of the duties, functions or powers of that office;
- (p) mentioning any thing after the words 'includes', 'included' or 'including' does not limit the meaning of any thing mentioned before those words;
- (q) a reference to a day is to be interpreted as the period of time in Tasmania commencing at midnight and ending 24 hours later;
- (r) reference to a time or date in connection with the performance of an obligation by a party is a reference to the time or date in Hobart, Tasmania, even if the obligation is to be performed elsewhere; and
- (s) references to '\$' and 'dollars' are to Australian dollars.

### **1.3 Headings**

Headings are included for convenience only and do not affect the interpretation of this Deed.

### **1.4 No rule of construction applies to disadvantage party**

In relation to the interpretation of this Deed, no rule of construction is to apply to the disadvantage of a party because that party was responsible for the preparation of this Deed or any part of it.

### **1.5 Information Table**

- (a) An Item that has not been completed will be taken to be 'not applicable'.
- (b) Unless the context otherwise requires, expressions defined in the Information Table have the same meanings when used in other parts of this Deed.

---

## 2 Grant

### 2.1 Agreement to provide Grant

Subject to the terms of this Deed, the Grantor will provide to the Recipient the monetary grant set out in Item 2 for use by the Recipient for the Approved Purpose in accordance with this Deed.

### 2.2 Acknowledgments

The Recipient acknowledges and agrees that:

- (a) the Grantor's financial assistance to the Recipient in respect of the Approved Purpose is limited to the Grant;
- (b) nothing in this Deed requires the Grantor to provide any further financial assistance to the Recipient in respect of the Approved Purpose; and
- (c) the Grantor is not responsible for any liabilities incurred by the Recipient, or any obligations entered into by the Recipient, as a result of or arising out of, the Recipient's obligations under this Deed or in respect of the Approved Purpose.

---

## 3 Payment of Grant to Recipient

### 3.1 Method of Grant payment

Subject to clause 3.2, the Grantor will pay the Grant to the Recipient in the manner specified in Item 3. If no method of payment is specified in Item 3, the method of payment will be as determined by the Grantor.

### 3.2 Conditions affecting Grant payment

- (a) **(Conditions precedent):** If Item 4 includes any conditions precedent to the payment of the Grant, then the obligation of the Grantor to pay the Grant or part of the Grant is subject to the prior and continuing satisfaction of those conditions precedent (except for any of those conditions precedent waived in writing by the Grantor).
- (b) **(Default Events):** The Grantor is not required to pay the Grant (or if the Grant is payable by instalments, any instalment of the Grant) to the Recipient if a Default Event has occurred and has not been remedied to the satisfaction of the Grantor.
- (c) **(Requirement for tax invoice):** If the Grant, or any instalment of the Grant, is subject to GST, the Grantor is not required to pay the Grant (or the relevant instalment) until the Grantor has received from the Recipient a correctly rendered tax invoice in accordance with clause 11.

---

## 4 Application of Grant and related matters

### 4.1 Application of Grant for Approved Purpose

- (a) The Recipient must only use the Grant to undertake the Approved Purpose.
- (b) The Recipient must not change the Approved Purpose without the prior written approval of the Grantor, which approval may be given or withheld in the Grantor's absolute discretion.

- (c) The Recipient must undertake the Approved Purpose exercising reasonable skill, care and attention.

#### **4.2 Commencement of Approved Purpose**

The Recipient must substantially commence (to the Grantor's satisfaction) the Approved Purpose by the date shown in Item 5 or such later date, if any, approved in writing by the Grantor.

#### **4.3 Completion of Approved Purpose**

The Recipient must complete the Approved Purpose by the date shown in Item 6 or such later date, if any, approved in writing by the Grantor.

#### **4.4 Compliance with Law**

The Recipient must comply with all applicable Laws in expending the Grant and in carrying out the Approved Purpose.

#### **4.5 Financial records**

- (a) The Recipient must keep and maintain proper accounts, records and financial statements showing, the receipt, use and expenditure of the Grant and the carrying out of the Approved Purpose.
- (b) The Recipient's financial statements must show, as separate items, the receipt, use and expenditure of the Grant.
- (c) The Recipient must allow the Auditor-General of Tasmania (or his or her nominee) to audit, inspect, and to take copies of, the Recipient's accounts, records and financial statements relating to the receipt, use and expenditure of the Grant.

#### **4.6 Notice by Recipient of adverse matters**

The Recipient must immediately notify the Grantor in writing of:

- (a) the occurrence of any matter, event or thing, occurring after the date of this Deed, that adversely affects or materially delays the Recipient carrying out the Approved Purpose in accordance with, or the performance by the Recipient of its obligations under, this Deed;
- (b) any breach of this Deed by the Recipient; or
- (c) the occurrence of any Default Event.

---

## **5 Publicity concerning Grant and Approved Purpose**

The Recipient must include in any correspondence, promotional material, public (including media) announcement, advertising material, or other publication concerning the Approved Purpose, an acknowledgement that the Approved Purpose is assisted by a grant from the Grantor. The acknowledgement must be in a form and substance approved in writing by the Grantor.

---

## **6 Repayment of Grant by Recipient**

### **6.1 Repayment obligation**

The Recipient must repay to the Grantor on demand in writing by the Grantor:

- (a) any part of the Grant that is not required by the Recipient to carry out the Approved Purpose;
- (b) any part of the Grant that is used by the Recipient for a purpose that is not an Approved Purpose; and
- (c) the Grant (or such part of the Grant as may be determined by the Grantor in its absolute discretion) if:
  - (i) the Recipient does not complete the Approved Purpose by the date shown in Item 6 or such later date, if any, approved in writing by the Grantor;
  - (ii) this Deed is terminated by the Grantor in accordance with clause 9; or
  - (iii) a Default Event occurs.

---

## **7 Review, monitoring, audit, reports and related matters**

### **7.1 Review, monitoring or audit of Relevant Matters**

The Grantor may from time to time review, monitor or audit any Relevant Matter. The Recipient must in connection with any such review, monitoring or audit by the Grantor comply with any reasonable directions of the Grantor.

### **7.2 Reporting**

- (a) The Recipient must provide to the Grantor the reports and other documents (if any) specified in Item 7.
- (b) The Recipient must provide to the Grantor such other reports and documents as required by the Grantor from time to time in connection with any Relevant Matter. Unless otherwise stated in Item 7, nothing in that Item limits the reports or frequency of reports that the Grantor may require under this clause 7.2(b).

---

## **8 Representations and warranties**

### **8.1 Warranties**

The Recipient represents and warrants to the Grantor that all information given, and each statement made, to the Grantor by the Recipient or its agents concerning any application for the Grant, is true, correct and not misleading in any way.

### **8.2 No reliance by the Recipient**

The Recipient acknowledges that it has not entered into this Deed in reliance on any representation, warranty, promise, statement or undertaking made by the Grantor or any person on behalf of the Grantor.

---

## **9 Default Events and termination**

### **9.1 Default Events**

Each of the following events is a Default Event for the purposes of this Deed:

- (a) **(Breach not capable of being remedied):** If the Recipient breaches any of its obligations under this Deed and the breach is not capable of being remedied.

- (b) **(Failure to remedy breach):** If:
  - (i) the Recipient breaches any of its obligations under this Deed;
  - (ii) the breach is capable of being remedied; and
  - (iii) the Recipient fails to remedy the breach within the period (being a period of not less than five Business Days) specified by the Grantor in a notice given to the Recipient detailing the breach.
- (c) **(Repudiation):** If the Recipient repudiates this Deed.
- (d) **(Natural person):** If the Recipient is a natural person, at any time before the Recipient has performed all of its obligations under this Deed, the Recipient:
  - (i) dies;
  - (ii) becomes an insolvent under administration (as defined in section 9 of the *Corporations Act 2001* (Cwlth)), or any action is taken which could result in that event; or
  - (iii) ceases to be of full legal capacity.
- (e) **(Body corporate related events):** If the Recipient is a body corporate, at any time before the Recipient has performed all of its obligations under this Deed:
  - (i) the Recipient becomes an externally administered body corporate (as defined in section 9 of the *Corporations Act 2001* (Cwlth));
  - (ii) the Recipient is dissolved, wound-up or its registration is cancelled;
  - (iii) any process or action is commenced or taken which could lead to an event mentioned in clause 9.1(e)(ii); or
  - (iv) in the opinion of an Authorised Officer for the Grantor, the corporate governance or administration of the Recipient is materially deficient or unsatisfactory.
- (f) **(Representation):** If any representation or warranty by the Recipient in this Deed is untrue, false or misleading when made or repeated.

## 9.2 Termination - Default Events

In addition to any other Rights, if a Default Event occurs, the Grantor may terminate this Deed by notice in writing to the Recipient. The termination takes effect when the Grantor's notice is taken to have been received by the Recipient in accordance with clause 12.3 (or any later date specified in the notice).

---

## 10 Special terms and conditions

- (a) The special terms and conditions (if any) in Item 8 form part of this Deed.
- (b) If there is any inconsistency between the special terms and conditions in Item 8 and another provision of this Deed, the special terms and conditions override the other provision to the extent of the inconsistency.
- (c) A special term or condition in Item 8 is taken not to be inconsistent with another provision of this Deed if the special term or condition and the other provision of this Deed are both capable of being complied with.

- (d) To avoid doubt and without limiting the operation of clause 13.14, any Right contained in Item 8 is in addition to any other Rights provided for in this Deed or at Law.

---

## 11 GST

- (a) Unless otherwise stated in this Deed, all amounts payable by one party to another party are exclusive of GST.
- (b) If GST is imposed or payable on any supply made by a party under this Deed, the recipient of the supply must pay to the supplier, in addition to the GST exclusive consideration for that supply, an additional amount equal to the GST exclusive consideration multiplied by the prevailing GST rate. The additional amount is payable at the same time and in the same manner as the consideration for the supply.
- (c) A party that makes a taxable supply under this Deed must provide a valid tax invoice to the recipient of the supply.
- (d) A party's right to payment under clause 11(b) is subject to a valid tax invoice being delivered to the party liable to pay for the taxable supply.
- (e) If the consideration for a supply under this Deed is a payment or reimbursement for, or contribution to, any expense or liability incurred by the supplier to a third party, the amount to be paid, reimbursed or contributed in respect of the expense or liability will be the amount of the expense or liability net of any input tax credit to which the supplier is entitled in respect of the expense or liability.
- (f) Where any amount payable under this Deed is paid by being set-off against another amount, each amount must be calculated in accordance with this clause 11 as if it were an actual payment made pursuant to this Deed.
- (g) Unless the context otherwise requires, expressions used in this clause 11 that are defined in the GST Laws have the meanings given to those expressions in the GST Laws.

---

## 12 Notices

### 12.1 Notice requirements

- (a) A notice, certificate, consent, application, waiver or other communication (each a **Notice**) under this Deed must be:
- (i) in legible writing in the English language;
  - (ii) subject to clauses 12.1(b) and 12.1(c), signed by or on behalf of the sender or by a lawyer for the sender;
  - (iii) marked for the attention of the person or position (if any) specified in the Details applicable to the intended recipient of the Notice or, if the intended recipient has notified otherwise, marked for attention in the way last notified; and
  - (iv) left or sent in accordance with clause 12.2.

- (b) A printed or copy signature is sufficient for the purposes of sending any Notice by facsimile.
- (c) A Notice sent by email is taken to have been signed by the sender.
- (d) A Notice must not be given orally.

## **12.2 Method and address for delivery**

- (a) Subject to clause 12.2(b), a Notice must be:
  - (i) left at the intended recipient's address set out in the Details;
  - (ii) sent by prepaid ordinary mail (or prepaid airmail, if from one country to another country) to the intended recipient's address set out in the Details;
  - (iii) sent by facsimile to the intended recipient's facsimile number (if any) set out in the Details; or
  - (iv) sent by email to the intended recipient's email address (if any) set out in the Details.
- (b) If the intended recipient of a Notice has notified the sender of another address, facsimile number or email address for the purposes of receiving Notices, then subsequent Notices to that intended recipient must be left at or sent to the address, facsimile number or email address (as applicable) last notified by that intended recipient.

## **12.3 Time of receipt**

- (a) Subject to clause 12.3(b), a Notice is taken to have been received by the intended recipient:
  - (i) if left at the intended recipient's address, at the time of delivery;
  - (ii) if sent by prepaid ordinary mail, on the third Business Day after the day of posting, or if sent by prepaid airmail from one country to another country, on the tenth Business Day after the day of posting;
  - (iii) if sent by facsimile, at the time shown in the transmission report as the time when the whole Notice was sent; and
  - (iv) if sent by email, four hours after the time the email was sent (as recorded by the device from which the email was sent) provided that the sender has not received an automated message that the email has not been delivered.
- (b) If a Notice is received by a recipient on a day that is not a Business Day or after 4.00pm on a Business Day, the Notice is taken to be received at 9.00am on the next Business Day.
- (c) A Notice is effective from the time it is taken to have been received in accordance with clauses 12.3(a) and 12.3(b) (unless a later time is specified in the Notice, in which case the notice takes effect from that time).

---

# **13 Miscellaneous**

## **13.1 Governing law**

This Deed is governed by the Laws applying in Tasmania.

### **13.2 Dispute jurisdiction**

The parties submit to the non-exclusive jurisdiction of courts with jurisdiction in Tasmania, and any courts that may hear appeals from those courts, in respect of any proceedings in connection with this Deed.

### **13.3 Entire agreement clause**

- (a) This Deed forms the entire agreement of the parties in respect of its subject matter. The only enforceable obligations of the parties in relation to the subject matter of this Deed are those that arise out of the provisions contained in this Deed. All prior agreements in relation to the subject matter of this Deed are merged in and superseded by this Deed unless expressly incorporated in this Deed as an annexure, an appendix, an attachment or by reference.
- (b) Nothing in clause 13.3(a) affects the Grantor's Rights in connection with this Deed in relation to any information given, or statement made, to the Grantor by the Recipient, its employees or agents concerning any application for the Grant.

### **13.4 Liability**

An obligation of, or a representation, a warranty or an indemnity by, two or more parties (including where two or more persons are included in the same defined term) under or in respect of this Deed, binds them jointly and each of them severally.

### **13.5 Benefit**

An obligation, a representation, a warranty or an indemnity in favour of two or more parties (including where two or more persons are included in the same defined term) is for the benefit of them jointly and each of them severally.

### **13.6 Severance**

If a provision of this Deed is or at any time becomes illegal, prohibited, void or unenforceable for any reason, that provision is severed from this Deed and the remaining provisions of this Deed:

- (a) continue to be enforceable; and
- (b) are to be construed with such additions, deletions and modifications of language as are necessary to give effect to the remaining provisions of this Deed.

### **13.7 Counterparts**

- (a) This Deed may be entered into in any number of counterparts.
- (b) A party may execute this Deed by signing any counterpart.
- (c) All counterparts, taken together, constitute one instrument.

### **13.8 Further assurance**

The parties agree to do or cause to be done all such acts, matters and things (including, as applicable, passing resolutions and executing documents) as are necessary or reasonably required to give full force and effect to this Deed.

### **13.9 No partnership or agency**

- (a) Nothing contained or implied in this Deed will:
  - (i) constitute, or be taken to constitute, a party to be the partner, agent or legal representative of another party for any purpose;

- (ii) create, or be taken to create, a partnership or joint venture; or
  - (iii) create, or be taken to create, an agency or trust.
- (b) The Recipient must not represent or hold itself out to be a partner, joint venturer, agent or representative of the Grantor.

### **13.10 Legal costs**

Each party must bear their own costs in preparing and negotiating this Deed.

### **13.11 Amendment**

This Deed may only be amended or supplemented in writing signed by the parties.

### **13.12 Waiver**

- (a) A failure or delay in exercising a Right does not operate as a waiver of that Right.
- (b) A single or partial exercise of a Right does not preclude any other exercise of that Right or the exercise of any other Right.
- (c) A Right may only be waived in writing, signed by the party to be bound by the waiver. Unless expressly stated otherwise, a waiver of a Right is effective only in the specific instance and for the specific purpose for which it was given.

### **13.13 Successors and assigns**

This Deed is binding on and benefits each party and, unless repugnant to the sense or context, their respective administrators, personal representatives, successors and permitted assigns.

### **13.14 Rights cumulative**

Each Right of the Grantor provided for in this Deed:

- (a) operates independently of any other Right of the Grantor provided for in this Deed; and
- (b) is cumulative with, and does not exclude or limit, any other Right of the Grantor, whether at Law or pursuant to any other agreement, deed or document.

### **13.15 Set-off**

The Grantor may set-off against any moneys payable by the Grantor to the Recipient under this Deed any debt or other moneys from time to time due and owing by the Recipient to the Grantor. This right of set-off does not limit or affect any other right of set-off available to the Grantor.

### **13.16 No assignment**

The Recipient must not assign any of its Rights and obligations under this Deed except with the prior written consent of the Grantor.

### **13.17 Disclosure**

- (a) Despite any confidentiality or intellectual property right subsisting in this Deed, a party may publish all or any part of this Deed without reference to another party.
- (b) Nothing in this clause derogates from a party's obligations under the *Personal Information Protection Act 2004* (Tas) or the *Privacy Act 1988* (Cwlth).

### **13.18 Determination**

Where the Grantor is required or entitled to form or hold an opinion or view under or in relation to this Deed, that opinion or view may be formed or held by an Authorised Officer for the Grantor. This clause does not limit any other way in which the Grantor may otherwise form or hold an opinion or view under or in relation to this Deed.

### **13.19 Consent and approvals**

- (a) This clause applies to any consent or approval which the Recipient must obtain from the Grantor in accordance with this Deed. For the avoidance of doubt, this clause does not apply to any consent or approval to be given under any legislation.
- (b) A request for consent or approval must be made in writing.
- (c) A consent or approval for the purposes of this Deed is not effective unless given in writing.
- (d) A consent or approval may be given subject to reasonable conditions.
- (e) A Recipient must comply with any conditions subject to which the consent or approval is given. To the extent that the Recipient fails to comply with the condition, that failure is taken to be a breach of this Deed.

### **13.20 Doctrine of merger**

The doctrine or principle of merger does not apply to this Deed or to anything done under or in connection with this Deed. Accordingly, no Right or obligation of a party is merged in any thing done pursuant to this Deed.

### **13.21 No interference with executive duties or powers**

Nothing in this Deed is intended to prevent, is to be taken to prevent, or prevents, the free exercise by the Governor, by any member of the Executive Council, or by any Minister of the Crown, of any duties or authorities of his or her office. Any provision of this Deed that is inconsistent with this clause is of no legal effect to the extent of the inconsistency.

### **13.22 Surviving provisions and termination**

- (a) The termination of this Deed does not affect or limit the operation or effect of clauses or parts of this Deed:
  - (i) that are expressed to survive the termination of this Deed;
  - (ii) that, at Law, survive the termination of this Deed; or
  - (iii) that are necessary to survive the termination of this Deed:
    - (A) to give full force and effect to the parties' respective Rights, obligations and liabilities on or after the termination of this Deed;
    - (B) to enable a party to make, enforce or defend any claims related to this Deed; or
    - (C) to give full force and effect to the operation of clause 13.22(b) or clause 13.22(c).
- (b) The termination of this Deed does not affect any claims related to, or any Rights, releases, obligations or liabilities accrued or incurred under, this Deed before the date on which this Deed is terminated.

- (c) Nothing in this clause 13.22 affects or limits the operation of another provision of this Deed which gives a party Rights, or imposes obligations on a party, on or after the termination of this Deed.

**Executed as a deed**

# Signing

## Execution by the Grantor

Executed as a deed on behalf of **The Crown in Right of Tasmania** by the person named below in the presence of the witness named below:

Signature:  
→

Being a person who has authority to sign this Deed on behalf of the Grantor

\*Print name and position:

Witness' signature:  
→

\*Witness print name and position:

\*Use BLOCK LETTERS

\*Witness print address:

## Execution by the Recipient

The common seal of the Recipient was hereunto affixed in the presence of:

Common seal:  
→

Signature:  
→

Signature:  
→

\*Print name and office held:

\*Print name and office held:

\*Use BLOCK LETTERS

Note: If the Recipient has adopted the 'Model Rules', the common seal must be affixed in the presence of: two members of its committee; or one member of its committee and the public officer of the Recipient or any other person the committee has appointed for that purpose.

## Annexure A – Acknowledgement of Funding

---

The Recipient must acknowledge the support of the Tasmanian Government, as follows:

1. the Recipient must use the Tasmanian Government 'supported by' logo (as shown below) to promote the Approved Purposes.
2. the Recipient must include the logo in all marketing relating to the Approved Purpose including, but not limited to:
  - advertisements
  - newsletters, including electronic newsletters
  - media releases
  - press, radio and television advertising
  - display material
  - recipient's website homepage.
3. the Recipient must include the following statement on their social media site/s in the 'About' section: **'the [ORGANISATION/ PROJECT] is supported by the Tasmanian Government'**.
4. to ensure the correct logo is used appropriately for marketing and promotional purposes, all materials must be approved by the Department of Premier and Cabinet (DPAC) prior to publication/promotion.

Please contact Grants on 1800 204 224 to arrange supply of the logo.

5. the logo must be reproduced according to the following specifications:

### **Logo colour**

The logo may only appear in:

- black (mono)
- white (reversed out of a solid colour background).

### **Minimum size**

The logo must always be at least 20mm wide if vertical and 30mm wide if horizontal.

A smaller version can only be used if the print surface area demands it (i.e. pens, badges). A certain amount of space must be maintained around the logo – refer to the Tasmanian Government Communications website:

[tas.gov.au/communications](https://tas.gov.au/communications) and search for 'size' details.

## Please note

- 1 Do not change the format, colour, shape or typeface (font) of the logo.
- 2 Take care not to distort the logo when resizing – its height and width must change in proportion, so it is not squeezed or squashed.
- 3 Do not create your own version of the logo or add any text; use only the versions supplied.
- 4 Other variations of the logo are available from Grants, DPAC.
- 5 If the Tasmanian Government logo appears with other supporter logos, the words 'Supported by' may be removed.



## [LBT Committee] Fwd: Request for loan of equipment- Art and Music Exhibition - 16, 17 and 18 January - Castle Forbes Bay Recreation Club



From [LBT Secretary](#)

Sender [Committee](#)

To [committee@lbt.org.au](mailto:committee@lbt.org.au)

Date Tue 13:07

 Summary  Headers  Plain text

---

**From:**

Marguerite Porte <marg.porte1@gmail.com>

**Sent:** 14 July 2025 12:29:18 pm AEST

**To:**

sec@lbt.org.au

**Subject:**

Request for loan of equipment- Art and Music Exhibition - 16, 17 and 18 January - Castle Forbes Bay Recreation Club

Dear Secretary and LBT committee members,

The Castle Forbes Bay Recreation Club use the Art and Music Exhibition to raise funds to improve the facilities of the club and promote the facility to the wider community. It is run entirely by volunteers.

As a member of the committee for the Art and Music Exhibition at Castle Forbes Bay, I am making a request of the Living Boat Trust to lend us the following equipment for the event which will be held on the Friday, Saturday and Sunday 16, 17 and 18 January 2026.

Chairs

Fold up tables

Large tent - and any other marquees that may be available

Plastic bowls

The LBT has, in past years, generously lent CFB Rec Club equipment for the event and I trust that this arrangement can be continued.

Could you please provide a written response to this request.

Yours sincerely

Marguerite Porte - Curator Art and Music Exhibition

LBT Secretary

---

--

Committee mailing list

[Committee@lbt.org.au](mailto:Committee@lbt.org.au)

[http://lbt.org.au/mailman/listinfo/committee\\_lbt.org.au](http://lbt.org.au/mailman/listinfo/committee_lbt.org.au)



# CKB SOLUTIONS

COMMERCIAL KITCHENS AND BARS

Design to install

ABN: 23618752864  
21 Cranswick Court, Lenah Valley, TAS 7008  
Craig's Mobile: 0419538815  
[www.ckbsolutions.com.au](http://www.ckbsolutions.com.au)  
sales@ckbsolutions.com.au

Email: Admin@eurotech.net.au

Attention: Andrew Richie

Dear Andrew

It is our pleasure in submitting the following information and quotations on the following under counter dishwasher as discussed from the Silver Chef second hand special list.

One only **Hobart CG-90B** under counter dishwasher.

### Features

- ✓ Drain pump
- ✓ Detergent dispenser
- ✓ Rinse aid dispenser
- ✓ Dish rack
- ✓ Glass rack
- ✓ Cutlery holder
- ✓ Adjustable feet
- ✓ S/S finish
- ✓ Surface scratches
- ✓ 15 Amp 1 Phase
- ✓ 600mmW x 600mmD x 830mmH
- ✓ 60KG



Asset number: 769003

Location: Brisbane, QLD

Default Title

Purchase outright: \$3,850.00 Was ~~\$7,883.70~~

**Hold onto the cash you need to run and grow your business!**

**Rent-Try-Buy for just: \$6.98 /day** Was ~~\$14.29 /day~~ You save 51%

This unit is based in the Queensland warehouse and the was originally purchased on a silver chef contract in 2022 and returned in 2023, the unit has had only 12 months use and is in very good condition.

Freight from Queensland warehouse to Hobart is \$ 240.00

Warranty is 3 months parts and labour by Silver Chef

This unit has been reduced below the cost of the unit due to been in stock for a while.

It is available as an outright purchase, or it can be financed on the rent try buy.

If you require any additional information, please do not hesitate to contact me.

Kind regards

**CKB Solutions Pty Ltd**

Craig Briggs CFSP

**Managing Director**



Medhurst Equipment Pty Ltd

ABN: 88829342853

Medhurst Equipment 53 Burnett Street, North Hobart TAS 7000

Ph: 03 6234 8688, Fax: 03 6234 8154,

Email: accounts@medhurst.com.au

**QUOTE 25-00010116**



Sales Person: Colin C

Date: 11 Jul 2025

| CUSTOMER DETAILS  |                     |                   |              |
|-------------------|---------------------|-------------------|--------------|
| Billing           |                     | Delivery          |              |
| Living Boat Trust | P:0407816224        | Living Boat Trust | P:0407816224 |
| Andrew Ritchie    | Account#: FW-155384 | Andrew Ritchie    |              |
| 3337 Huon Highway |                     | 3337 Huon Highway |              |
| Franklin TAS 7113 |                     | Franklin TAS 7113 |              |
| Australia         |                     | Australia         |              |

**Order Comments**

Terms & Conditions

- 1) Quoted prices are valid for 14 days.
- 2) A 30% deposit is required on all orders (unless otherwise agreed) before stock is ordered, with the balance due prior to delivery.
- 3) Additional delivery charges may apply for locations outside Hobart CBD. Please check with your salesperson to confirm.
- 4) All prices are in Australian Dollars unless stated otherwise.
- 5) Spare part orders are final and non-refundable.
- 6) Goods remain the property of Medhurst Kitchen Equipment until paid in full—Retention of Title laws apply.
- 7) Full terms and conditions are available at [www.medhurstequipment.com.au](http://www.medhurstequipment.com.au).

Flexible Equipment Funding with SilverChef

SilverChef's Rent-Try-Buy offers flexible funding with low weekly payments, giving you the freedom to upgrade, swap, or buy equipment at a reduced rate within 12 months. Apply in just 5 minutes—no obligation. For more information, visit [www.silverchef.com.au](http://www.silverchef.com.au).

Receiver Signature: ..... Receiver Name (Print):

.....

Date: ...../...../.....

| DESCRIPTION:  | QTY: | UNIT PRICE:<br>(INC TAX) | TOTAL:<br>(EX TAX) | TOTAL:<br>(INC TAX) |
|---|------|--------------------------|--------------------|---------------------|
| <b>Undercounter Dishwasher C500 ClassEQ</b><br>(ID: 147713, 853V0001, C500)<br>Size: Per Unit | 1    | \$5,588.00               | \$5,080.00         | \$5,588.00          |

Freight: \$0.00 \$0.00

|                                    |                     |   |                     |            |            |
|------------------------------------|---------------------|---|---------------------|------------|------------|
| <b>OUR DIRECT DEPOSIT DETAILS:</b> | <b>TOTAL ITEMS:</b> | 1 | <b>GRAND TOTAL:</b> | \$5,080.00 | \$5,588.00 |
|------------------------------------|---------------------|---|---------------------|------------|------------|

ACC Name: Medhurst Equipment Pty Ltd  
BSB: 017-010  
ACC: 16 71471

|                     |                   |
|---------------------|-------------------|
| <b>TOTAL PAID:</b>  | \$0.00            |
| <b>ROUNDING:</b>    | \$0.00            |
| <b>TOTAL GST:</b>   | \$508.00          |
| <b>BALANCE DUE:</b> | <b>\$5,588.00</b> |



### TECHNICAL DATA

|   |                               |
|---|-------------------------------|
| Power cord                              | 15 A single phase plug & lead |
| Wash tank temperature                   | 55 - 60°C                     |
| Rinse water temperature (booster tank)  | Minimum 82°C                  |
| Low temp cut-out (thermostop) activated | Yes                           |
| Cycle times                             | 1. 60 sec.<br>2. 150 sec.     |
| Water consumption                       | 2.3 litres                    |
| Tank capacity                           | 25 litres                     |
| Tank heating                            | 1.8 kW                        |
| Power supply                            | 240/50/1 - 15 A               |
| Booster loading                         | 1.9 kW                        |
| Total loading                           | 2.4 kW                        |
| Pump capacity                           | 340 watts                     |
| Loading height                          | 360 mm                        |

### PRODUCT ADVANTAGES

- Easy-to-use electronic controls with 2 cycles 60 & 150 seconds
- Digital temperature gauges
- Suits all racks up to 500x500mm - stainless steel grid shelf supports all rack sizes
- Re-circulating & low 2.3 litre rinse volume machine
- Double skin door for strength & durability for loading machine
- Usable chamber height of 360mm
- Polypropylene wash & rinse arm with patented WIDE ANGLE FAN nozzle to maximise wash & rinse performance
- Self-cleaning cycle on drain out
- Full width wash tank strainers & wash pump inlet strainer to ensure machine reliability
- "Connect & use"- fill & drain hoses, pump-out drain, chemical dispensers & power lead / plug included for quick & easy installation
- Rear castors & adjustable front feet for easy cleaning
- Includes 1 x plate rack, 1 x flat rack & 1 x cutlery holder
- WATERMARK approved
- NOT SUITABLE FOR USE WITH REVERSE OSMOSIS SYSTEMS
- MADE IN GERMANY

### CONNECTIONS

|                               |                          |
|-------------------------------|--------------------------|
| ① Drain hose                  | 2,000 mm   ID20/OD25     |
| ② Supply hose                 | 2,000 mm   R 3/4"        |
| Flow pressure                 | 3.0 -6 bar (300-600 kPa) |
| Max. supply water temperature | 60°C                     |
| Required flow rate            | 5 l/min                  |
| ③ Power cord                  | 2,000 mm                 |
| Supply hose for               |                          |
| ④ Detergent                   | 2,500 mm                 |
| ⑤ Rinse aid                   | 2,500 mm                 |

### DIMENSIONAL DRAWING

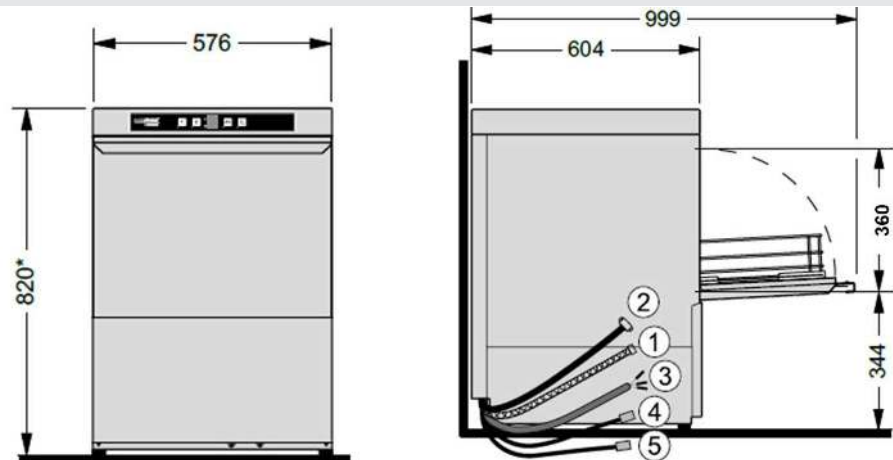

\* Thermostop guarantees required temperatures with cold water and / or 240 V connection, the actual cycle times extend accordingly.

For machine protection the water hardness should not exceed 3°dH, if higher we recommend using an integrated water softener or an external water softener of the product line HYDROLINE PROTECT.

# TECHNICAL DATA SHEET

## DISHWASHER | PE500

Code 4012336

12 Month Parts &amp; Labour Warranty



|   |  |                |                           |
|---|--|----------------|---------------------------|
| <b>EXTERNAL DIMENSIONS, WEIGHT &amp; VOLUME</b> | Overall Dimension (Width-Depth-Height) *Open | mm             | 575 x 605 (1005*) x 820   |
|   | Packaging Dimension (W x D x H)              | mm             | 690 x 670 x 980           |
|   | Gross Weight                                 | Kg             | 62                        |
|   | Net Weight                                   | Kg             | 56                        |
|   | Volume                                       | M <sup>3</sup> | 0.45                      |
| <b>CONSTRUCTION</b>                             | Rack Size                                    | mm             | 500 x 500                 |
|   | Distance Between Rails                       | mm             | 500 x 500                 |
|   | Rack's Drives/Frame Construction             |                | Embossed                  |
|   | Max Door/Hood Opening                        | mm             | 365                       |
|   | Max Glasses/Plate Height                     | mm             | 325                       |
|   | General Construction                         |                | Single Skin               |
|   | Door/Hood Construction                       |                | Double Skin               |
| <b>TANK</b>                                     | Tank Construction                            |                | Welded                    |
|   | Tank Volume                                  | Litre          | 20                        |
|   | Tank Heating Element                         | W              | 2200                      |
|   | Tank Surface Strainers                       |                | Yes - Composite           |
| <b>WASH PUMP</b>                                | Wash Pump Type                               |                | Double Flow               |
|   | Wash Pump Power                              | W              | 470                       |
|   | Wash Temperature                             | °C             | 60                        |
| <b>BOILER</b>                                   | Boiler Type                                  |                | Without Pressure          |
|   | Boiler Volume                                | Litre          | 6                         |
|   | Back-Flow System                             |                | Break Tank                |
|   | Boiler Heating Element                       | W              | 2730                      |
| <b>RINSE</b>                                    | Rinse Booster Pump                           |                | Yes                       |
|   | Rinse Booster Pump Power                     | W              | 200                       |
|   | Rinse Temperature                            | °C             | 80                        |
|   | Rinse Water Consumption                      | Litre/Rack     | 2.2                       |
|   | Optimal External Water Pressure              | Bar            | 1 - 4                     |
| <b>DRAIN</b>                                    | Drain System                                 |                | Partial Drain             |
|   | Drain Pump                                   |                | Standard Built In         |
| <b>RINSE AID &amp; DETERGENT DISPENSER</b>      | Rinse Aid Dispenser                          | Peristaltic    | Yes                       |
|   | Detergent Dispenser                          | Peristaltic    | Yes                       |
| <b>WASH</b>                                     | Wash Cycle                                   | Sec            | 60 - 120 - 150 Continuous |
|   | Self Cleaning - Drain                        |                | Yes                       |
| <b>POWER</b>                                    | Electric Power                               | W              | 3200                      |
|   | Electric Connection                          | V - Ph - Hz    | 240v 1n 50hz              |
|   | Fuse   | Amp            | 15                        |
| <b>WASH SOFTENER</b>                            | Water Softener                               |                | No                        |
| <b>INSTALLED PARTS</b>                          | Plates racks                                 | N°1            | Yes                       |
|   | Cutterly Rack                                | N°4            | Yes                       |
|   | Drain Hose                                   | N°1            | Yes                       |
|   | Fill Hose "Watermark"                        | N°1            | Yes                       |

# TECHNICAL DATA SHEET

## DISHWASHER | PE500

Code 4012336

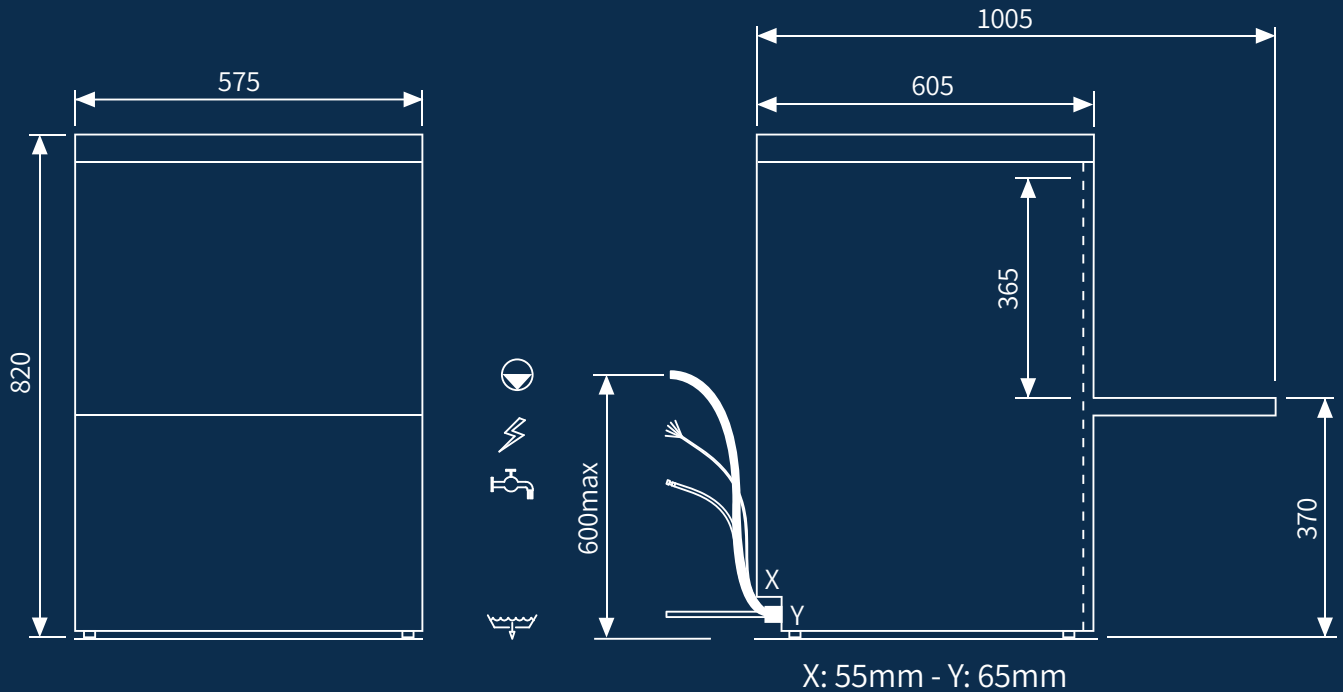

| DIMENSIONS & WEIGHT | Width      | 575mm |
|---------------------|------------|-------|
|                     | Depth      | 605mm |
|                     | Height     | 820mm |
|                     | Net Weight | 56Kg  |



Customer Experience: 03 6231 2055  
 Accounts Receivable: 07 3441 5860

Quote Date: 11 Jul 25  
 Quote No: 101705130  
 Valid Until: 25 Jul 25

Quote  
 POS HOBART  
 28A WARWICK STREET  
  
 NORTH HOBART

**Quotation Acceptance:**

**Name:** \_\_\_\_\_

**Position:** \_\_\_\_\_

**Signed:** \_\_\_\_\_ **Date:** \_\_\_\_\_

| Customer Code        | Customer Reference | Branch         |
|----------------------|--------------------|----------------|
| CASH70               |                    | HOBART         |
| Sales Contact        |                    | Sales Order No |
| HOBART STORE ACCOUNT |                    | 101705130      |

| Item Code | Item Description                        | Ordered | Shipped | B/Ord | UOM  | Item Price | Total (ex) | Total (inc) |
|-----------|---|---------|---------|-------|------|------------|------------|-------------|
| 4012336   | DISHWASHER U/C PE500 575X605X820MM      | 1.00    | 1.00    | 0.00  | EACH | 3,750.00   | 3,750.00   | 4,125.00    |
| 4069173   | DISHWASHER U/C ECOMAX 504 604X576X820MM | 1.00    | 1.00    | 0.00  | EACH | 4,488.00   | 4,488.00   | 4,936.80    |
|           |   |         |         |       |      |            |            |             |
|           |   |         |         |       |      |            |            |             |
|           |   |         |         |       |      |            |            |             |
|           |   |         |         |       |      |            |            |             |
|           |   |         |         |       |      |            |            |             |
|           |   |         |         |       |      |            |            |             |
|           |   |         |         |       |      |            |            |             |
|           |   |         |         |       |      |            |            |             |
|           |   |         |         |       |      |            |            |             |
|           |   |         |         |       |      |            |            |             |
|           |   |         |         |       |      |            |            |             |
|           |   |         |         |       |      |            |            |             |
|           |   |         |         |       |      |            |            |             |
|           |   |         |         |       |      |            |            |             |
|           |   |         |         |       |      |            |            |             |
|           |   |         |         |       |      |            |            |             |
|           |   |         |         |       |      |            |            |             |
|           |   |         |         |       |      |            |            |             |
|           |   |         |         |       |      |            |            |             |

**Terms and Conditions:**  
 This quotation is for the product only. Unless otherwise stated, delivery, unpacking & installation may incur additional charges.  
 Once your order is confirmed it cannot be cancelled or returned for credit unless authorised by a Reward Hospitality representative.  
 BUY IN items which are returned for credit will incur a 20% restocking fee plus associated freight costs.  
 Please ensure you refer to the manufacturers specifications for installation, power supply, warranty & maintenance information.  
 To place an order for the items quoted above, please confirm your acceptance of our terms & conditions by returning an official purchase order or by completing the relevant fields to the left & faxing to 03 6234 8553 or emailing hobart@tashotel.com.au.



SCAN HERE TO APPLY:



## Keep your cash in your business.

### Pay today with Rent-Try-Buy.

Terms and conditions apply. Customers should seek taxation, legal or other professional advice independent to their personal circumstances, before applying.

|   |                   |
|---|-------------------|
| Total Ex                                      | \$8,238.00        |
| GST   | \$823.80          |
| <b>Total</b>                                  | <b>\$9,061.80</b> |
| <b>EFT DETAILS:</b>                           |                   |
| COMMBANK<br>BSB: 064-000<br>ACCOUNT: 16233223 |                   |



## SALUS MARITIME

### MARINE CRAFT INSURANCE RISK EVALUATION



|   |   |                |
|---|---|----------------|
| OWNER: The Living Boat Trust  | POLICY/QUOTATION NUMBER:  |                |
| ADDRESS: Andrew Ritchie 3337 Huon Highway, Franklin, Tasmania, 7113 | SLIPPING DATE: 2 July 2025  |                |
| TELEPHONE NO: 0407816224  | INSPECTED AT: Port Huon Yacht Club                                      |                |
| EMAIL ADDRESS: andrew@aritchie.au                                   | VESSEL NAME: Nancy  |                |
| HIN/REGISTRATION/SAIL NO.: VG336Q                                   | <input type="radio"/> FLOAT <input checked="" type="checkbox"/> SLIPPED |                |
| BUILDER: A.A. Tucker Abel   | DESIGN: Fantail river launch  | RIG:           |
| DATE LAUNCHED: 1917   | LOA: 10.67m   |                |
| CONSTRUCTION MATERIAL - HULL: Huon Pine Carvel Planked              | DECK: Celery Top Pine Planked   | KEEL: Deadwood |



**SALUS MARITIME**  
ABN [82 008 428 437](https://abn.gov.au/abn/82008428437)  
23 Pipeclay Esplanade  
Cremorne Tasmania 7024

**WWW.SALUSMARITIME.COM**  
[contact@salusmaritime.com](mailto:contact@salusmaritime.com)  
Tel +61 (0) 402 108 301  
Marine Survey and Consultancy

## AGREEMENT ON COMMENCEMENT OF THE SURVEY

The purpose of this inspection and survey is to ascertain, insofar as possible within the limitations of visual and physical accessibility, through non-invasive and non-destructive means, the vessels current condition and value and thus documenting the vessels inventories and appendages and any deficiencies and non-compliance within the vessels structure and equipment.

Certain parts of structure, systems and equipment may be inaccessible without removing decks, tanks, bulkheads and headliners etc. and, in the case of cored structure where the drilling of core samples may be the only means of fully understanding the structures integrity. Coatings build up, corrosion, marine growth, excessive equipment and gear on board, and grime may hamper the surveyor's ability to inspect.

dirt

Components requiring access with tools or by dis-assembly have not been inspected. Some systems and component parts often give no readily detectable external indication of deterioration or failure. Cosmetic issues may be addressed where there is noted a significant effect on the market value of the vessel.

Testing of some components such as hull, rudders, shafts, skegs, cleats, chainplates, working machinery nuts, screws and bolts will require a moderate amount of force, such as the surveyor using a crowbar, hammer or chisel to test the vessels integrity. If the surveyed items are in acceptable condition they should not break, but occasionally due to pre existing corrosion, fatigue, delamination or other factor the items may break. Some examples may include but not be limited to;

- While sounding the hull with a hammer the hammer may penetrate the hull if the hull is not seaworthy
- While applying a liberal amount of force to the rudder or skeg it may crack
- While testing nuts, bolts or screws they may break.

The testing of these items is done in good faith to check their seaworthiness and responsibly of breakage and cost of subsequent repair shall be accepted by the owner. The surveyor shall not be liable for any breakages or damage that may occur during the survey.

Any screws, bolts or fittings removed will be replaced using sickaflex 291 or a corrosive inhibitor such as Tufgel. If the owner wishes for alternative sealant or more advanced boat building such as use of epoxy tit is the responsibility of the owner.

Non destructive testing (NDT) such as Ultrasonic thickness measurement, moisture content measurement, or the use of sprays or gells to check for cracks may be required or requested as part of the survey to ascertain the integrity of the hull, deck or spar. To enable correct analysis using NDT paint, polish and rust may need to be removed by scraping, sanding or wire brush. Salus maritime is not responsible for repair of paint or polish. It is the owners responsibility to re paint or polish on completion of the survey. Any destructive testing such as drilling holes for hull sampling or to ascertain moisture content will be agreed upon after agreement with the owner.

Electronic and electrical equipment has undergone testing by powering up or tuning on and is solely reliant on intended power source being available to the inspector. A complete analysis of the vessels electrical systems would require the services of a qualified marine electrician. Only the external condition of wiring, connections, switches and control boards have been visually made and reported.

The surveyor recommends that a qualified marine mechanic inspect all engines, generators, transmissions, sail-drives or stern-drives to determine the integrity of the equipment. Loose gear and accessories are neither inventoried nor inspected.

This survey is an opinion of the surveyor and based on the surveyor's knowledge and experience at the time of inspection. Within these parameters the surveyor will report on the hull, deck, vessel systems, running gear, cosmetic condition and provide a report on the forgoing. The surveyor cannot predict how the vessel, or its systems will perform over time and therefore this report is valid only at the time of survey.

The vessel was surveyed without the removal of any parts, such as screwed or nailed boards, anchors, chain, fixed partitions, instruments, spare parts, or miscellaneous materials in bilges and lockers and or any other fixed or semi fixed items. Inaccessible areas also preclude this inspection.

Furthermore, no determination of stability characteristics or inherent structural integrity has been made and no opinion is expressed with respect thereto.

The surveyor will endeavor to return the vessel to its found condition, however some items such as circuit breakers and battery switches may be left off and sea cocks may be left shut. It is the responsibility of the owner to conduct their own pre start checklist prior to recommencing boat operations.

If the owner is unhappy with the survey findings or the surveyors work, this survey can be discontinued at any time. By Reading this disclosure prior the survey the owner agrees to commence the surveys and understands that the surveyor is acting with best interests in the safety of the vessel and is not liable for any damage as a result of survey practices or defects identified during the survey.



**SALUS MARITIME**  
 ABN 82 008 428 437  
 23 Pipeclay Esplanade  
 Cremorne Tasmania 7024

**WWW.SALUSMARITIME.COM**  
 contact@salusmaritime.com  
 Tel +61 (0) 402 108 301  
 Marine Survey and Consultancy

This survey report represents the condition of the vessel on the above date and is the unbiased opinion of the surveyor. Salus Maritime Terms & Conditions are available on Salus website

## HULL CONSTRUCTION/CONDITION

|                      | CONDITION | COMMENTS/DETAILS/DESCRIPTION   |
|----------------------|-----------|--|
| Keel                 | Good      | Tasmanian Deadwood or Gum with 3mm laid glass overlay. Copper sheathing on base of keel.   |
| Keelbolts            | Good      | N/A  |
| Surface U/W          | Good      | Huon pine carvel planked over Blue gum/blackwood/celery top frames. Originally planks would have been roved to frames and corked. Planks have been screwed into frames and splined during refit and 3mm of Dinal/Biodiagonal glass laid over the hull to the waterline using epoxy. Dinal/Bio diagonal glass coated in an epoxy based paint system with CopperCoat antifouling. Three minor areas Dinal/Biodiagonal glass have separated from the hull and water has penetrated the layer between hull and Dinal/Biodiagonal glass. This is not of structural concern and will not sink the vessel, however, the delaminated dinal should be ground away, timber thoroughly dried (3-5 days with dry heat < 40°C), and the Dinal/Biodiagonal glass replaced to prevent spread of delamination. The longer this remains unattended the worse the problem will become. I would highly recommend this is attended to in the next quarter. |
| Surface A/W          | Good      | Huon pine carvel planked over Blue gum/blackwood/celery top frames. Original planks would have been roved to frames and corked. Planks have been screwed into frames and splined during refit and coated in an epoxy based paint system. Slight damage at the aft end of the keel above the waterline where the paint has cracked. This should be sanded back faired, then caulked or splined before repainting.   |
| Deck                 | Good      | Celery top over plywood in good condition. Some minor areas of caulking missing. This should be re caulked as soon as possible.  |
| Cockpit              | Good      | Cockpit extends into the cabin with exposed frames and stringers allowing full inspection of structure. Paint is coming away from the inside of the hull exposing bare timber. Loose paint on frames, stringers and planning need to be scraped and sanded back. A time consuming job and surely a labour of love. Exposed timber will rot or crack so this should be done as soon as possible. Consider purchasing a cover for the vessel to protect the interior from UV but keep air flow.  |
| Coach-House          | Good      | Huon pine cabin sides with plywood roof laid with celery top timber.   |
| Frames and stringers | Good      | Celery Top Pine, Blackwood and Blue Gum. Many frames original build from 1907, many sister frames introduced to re strengthen over the years and re fastened. Frames checked for rot in bilge and all accessible frames seemed in good condition.  |
| Longitudinals        | Good      | Celery top longitudinal in good condition. Require scrape and re paint in places.  |
| Bulkheads            | Good      | Three partial bulkheads.   |
| Cabin/Interior       | Good      | Cabin is "open plan" with minimal fitout and easily accessible. A large series of fitted chests nicely finished and fitted some time in 2000's running longitudinally along the centreline house batteries, safety equipment and general storage, while doubling up as seating.  |
| Marine Toilet        | n/a       | N/A  |
| Seacocks             | Good      | Engine intake below waterline on port side no longer used and closed.  |
| Skin Fittings        | Good      | 2 x skin fittings above waterline on port side for bilge water discharge in good condition.  |



**SALUS MARITIME**  
ABN 82 008 428 437  
23 Pipeclay Esplanade  
Cremorne Tasmania 7024

**WWW.SALUSMARITIME.COM**  
contact@salusmaritime.com  
Tel +61 (0) 402 108 301  
Marine Survey and Consultancy

|                          | CONDITION | COMMENTS/DETAILS/DESCRIPTION   |
|--------------------------|-----------|--|
|                          |           | 1 x skin fitting under transom above waterline for bilge water discharge in good condition.        |
| Cockpit Drains           | N/A       | Cockpit drains into bilge and then pumped out by bilge pumps.                                      |
| Siphon Breaks and Piping | N/A       |  |
| Propeller                | Good      | Bronze 4 blade 20" Propellor   |
| Propeller Shaft          | Good      | 1" Stainless steel shaft. Unknown last time removed and checked. Visually in good condition.       |
| Propeller Skeg           | N/A       |  |
| Sternland                | Good      | Lip seal grease packed gland arrangement.  |
| Rudder                   | Good      | Stainless steel rudder integral with 1 ¼" rudder stock   |
| Rudder Mounts            | Good      |  |
| Rudder Stock/Gland       | Good      | 1 ¼" stainless steel rudder stock  |
| Anodes                   | Good      | 2 x small anodes on base of rudder. Shaft anode not on shaft and being replaced at time of survey. |
| Steering Linkages        | Good      | Hydraulic steering appears recently fitted in good condition and installed correctly               |
| Auxiliary Steering       | Good      | Steel emergency tiller can be fitted through aft hatch.  |
| Chain Plates             | N/A       |  |
| Stemhead Fitting         | Good      |  |

**Hull Construction/Condition Recommendations:**

Hull is soundly constructed and restored in the 2000's by a professional shipwright. Small areas of delamination under the water line and flaking paint in the interior should be attended to as soon as possible to prevent further delamination and rot.



**SALUS MARITIME**  
ABN [82 008 428 437](https://abn.gov.au/abn/82008428437)  
23 Pipeclay Esplanade  
Cremorne Tasmania 7024

**WWW.SALUSMARITIME.COM**  
[contact@salusmaritime.com](mailto:contact@salusmaritime.com)  
Tel +61 (0) 402 108 301  
Marine Survey and Consultancy

## ELECTRICAL

|                        | CONDITION | COMMENTS/DETAILS/DESCRIPTION   |
|------------------------|-----------|--|
| MFD                    | N/A       |  |
| Instruments            | N/A       |  |
| Radar                  | N/A       |  |
| VHF                    | Good      | Icom VHF tested with Tas Maritime Radio Ch 16 and  |
| SSB                    | N/A       |  |
| AIS                    | N/A       |  |
| Autopilot              | N/A       |  |
| Solar                  | N/A       |  |
| Solar Controller       | N/A       |  |
| Inverter               | N/A       |  |
| Insulation Transformer | N/A       |  |
| Wiring                 | Good      | Vessel has been re wired to a high standard to accommodate LiPo batteries for powering electric drive.   |
| Circuit Breakers       | Good      | 12V and 48V circuits fused   |
| RCD                    | N/A       | .  |
| Battery                | Good      | 4 x EVP 12V power packs in series for 48V DC @ 25A to power circuit for main electric drive.<br><br>2 x AGM batteries fitted but not connected. It is the intention to use the AGM batteries for auxiliary power for the electric motor. |
| Battery Charger        | Good      | EV Power 48V 25A 240V Lithium battery charger  |
| Fridge/Freezer         | N/A       |  |
| Watermaker             | N/A       |  |

### Electrical Recommendations:

LiPo and AGM battery circuits should be independent with NO possibility for interconnection with the exception of a DC to DC charger. Direct Connection of LiPo and AGM circuits may result in an explosion.



**SALUS MARITIME**  
 ABN [82 008 428 437](https://abn.gov.au/abn/82008428437)  
 23 Pipeclay Esplanade  
 Cremorne Tasmania 7024

**WWW.SALUSMARITIME.COM**  
[contact@salusmaritime.com](mailto:contact@salusmaritime.com)  
 Tel +61 (0) 402 108 301  
 Marine Survey and Consultancy

## MOTOR INSTALLATION/CONDITION

|                     |                            |  |   |                                   |                                      |                              |   |
|---------------------|----------------------------|--|---|-----------------------------------|--------------------------------------|------------------------------|---|
| PETROL              | DIESEL                     | <input checked="" type="checkbox"/> ELECTRIC | <input checked="" type="checkbox"/> INBOARD | <input type="checkbox"/> OUTBOARD | <input type="checkbox"/> STERN DRIVE | <input type="checkbox"/> LEG | <input checked="" type="checkbox"/> SHAFT |
| BRAND:<br>Motenergy | MODEL No:<br>ME02010130001 | SERIAL No:<br>n/a                            | Voltage: 48V 10kW Peak                      |                                   | AGE: 2010                            |                              |   |

|                            | CONDITION | COMMENTS/DETAILS/DESCRIPTION  |
|----------------------------|-----------|---|
| Installation               | Good      | Original Frisco gas engine has been decommissioned but remains in place for visual appeal of the historic vessel. In lue of the Frisco engine the Motenergy Electric motor has been installed.<br><br>The installation of the electric motor has been done to a high standard by a competent electrical engineer. |
| Controls                   | Good      | Sevcon G4 control box on a long cable enabling control from helm.   |
| Exhaust                    | N/A       |   |
| Fuel Lines/Fittings        | N/A       |   |
| Fuel Tanks                 | N/A       |   |
| Filter                     | N/A       |   |
| Venting (Motor)            | N/A       |   |
| Connection & Lines (Motor) | N/A       |   |
| Electrical Harness         | Good      | Good wiring and all fused.  |
| Electrical Fitting         | Good      | Fitted to a high standard   |
| Stove                      | N/A       |   |
| Gas Bottles                | N/A       | Inc. Gas Compliance Plate No.:  |
| Gas Lines                  | N/A       |   |
| Bilge Pump - Manual        | Good      | Whale pump port aft tested  |
| Bilge Pump - Electric      | Good      | Rule 500 with auto float and higher alarm float aft.<br><br>Rule 500 with auto float fwd.   |

### Motor Installation/Condition Recommendations:

Original Frisco gas engine has been decommissioned but remains in place for visual appeal of the historic vessel. In lue of the Frisco engine the Motenergy Electric motor has been installed.

The installation of the electric motor has been done to a high standard by a competent electrical engineer.

The electric drive and slow turning propellor is sufficient for operation for inshore sheltered waters, rivers and lakes.



**SALUS MARITIME**  
ABN [82 008 428 437](https://abn.gov.au/abn/82008428437)  
23 Pipeclay Esplanade  
Cremorne Tasmania 7024

**WWW.SALUSMARITIME.COM**  
[contact@salusmaritime.com](mailto:contact@salusmaritime.com)  
Tel +61 (0) 402 108 301  
Marine Survey and Consultancy

## SAFETY EQUIPMENT

|                      | CONDITION | COMMENTS/DETAILS/DESCRIPTION  |
|----------------------|-----------|---|
| Anchor & Warp        | Good      | 15kg CQR anchor in good condition, 20m 6mm SS chain and length of nylon warp. |
| Flares               | Good      | 4 x Parachute Flares, 2 x red hand flares in date                             |
| Fire Extinguisher    | Good      | 1 x 3.5kg CO2, 1 x 1kg DCP. Fire blanket                                      |
| Spot Light           | Good      | Hand held portable type   |
| Lifejackets          | Good      | 14 x SOLAS style life jackets   |
| Navigation Lights    | Good      |   |
| Life Raft            | N/A       |   |
| Pulpits              | N/A       |   |
| Pushpits             | N/A       |   |
| Stanchions/Lifelines | N/A       |   |
| EPIRB                | N/A       |   |
| Emergency VHF        | N/A       |   |

**Safety Equipment Recommendations:**

Safety equipment in good condition. VHF radio tested with Tas Maritime Radio.



**SALUS MARITIME**  
ABN [82 008 428 437](https://abn.gov.au/abn/82008428437)  
23 Pipeclay Esplanade  
Cremorne Tasmania 7024

**WWW.SALUSMARITIME.COM**  
[contact@salusmaritime.com](mailto:contact@salusmaritime.com)  
Tel +61 (0) 402 108 301  
Marine Survey and Consultancy

## GENERAL REMARKS AND RECOMMENDATIONS

RESTRICTED WATERS       OPEN WATERS

This survey report represents the condition of the vessel on the above date and is the unbiased opinion of the surveyor. No determination of stability characteristics or inherent structural integrity has been made and no opinion is expressed with respect thereto

I certify that, to the best of my knowledge and belief, the statements of fact contained in this report are true and correct. The reported analysis, opinions and conclusions are limited only by the reported assumptions and limiting conditions and are my personal unbiased opinions and conclusions. The report is prepared solely for the benefit of the client to whom it is addressed and by whom it was commissioned.

Nancy is a historic river craft built in 1907 and was extensively restored in the early 2000's by a QLD shipwright before returning to Tasmania. Nancy is a wooden boat and some general wooden boat maintenance is required to keep her in good condition.

Below the waterline there were three section of Dynal/fiberglass delamination that should be seen to within the next six months to prevent further spread of the delamination. Nancy is watched over by numerous members of the Living Boat Trust. It is in the opinion of the surveyor that the delamination is unlikely to cause the vessel to leak, or that it compromises the structural integrity of the vessel.

With love, care, and regular maintenance, there is no reason for Nancy to continue her voyages for another 107 years.

Authorised Marine Surveyor     Authorised Shipwright

Name: RICHARD HEWSON  
AIMS MEMBER 824  
IIMS MEMBER H1358  
AMSA DCV SURVEYOR 9289-1214 0  
Trading Name: SALUS MARITIME  
Email Address: [CONTACT@SALUSMARITIME.COM](mailto:CONTACT@SALUSMARITIME.COM)

Signature:

Date:

Contact No: 0402108301

# PHOTOGRAPHS

